

The GLE Coupé



Mercedes-Benz



A blurred city street scene at night. In the background, a modern building with a grid-like facade of light and dark panels is visible. The building has large glass windows and a circular logo on its corner. The street is dark with white crosswalk markings, and the overall scene is lit with warm, golden light, possibly from streetlights or building lights. The foreground is heavily blurred, suggesting motion.

Ready to make your mark?

Then take a seat. The new GLE Coupé is made to let itself go and take every corner of the world by storm. With its sensationally sporty design. A revolutionary new cockpit. And fully active suspension that raises the benchmark in its class.





A silver Mercedes-Benz GLE Coupé is shown from a rear three-quarter view, driving on a road at night. The background is blurred, suggesting motion. The car's rear features include a large red taillight, a black rear bumper with dual exhaust tips, and a large alloy wheel with a Mercedes-Benz logo. The license plate is partially visible.

Some personalities are hard to miss.

The new GLE Coupé really stands out. With a sensational design that is more sporty and stylistically confident than ever. A less upright windscreen, low body and sloping rear line form the elegant silhouette. Wheels of up to 55.9 cm (22 inches) in size emphasise the SUV character of the GLE Coupé.



A detailed view of the driver's side of a Mercedes-AMG GT. The steering wheel is black with red stitching and the Mercedes-Benz logo. The dashboard is a wide, seamless glass panel housing two large digital displays. The left display shows a tachometer with a needle at 2000 RPM and a speedometer at 45 km/h. The right display shows a navigation map with a blue route and various icons. Below the dashboard are four air vents and a control panel with buttons and a gear selector. The interior is dark with red stitching on the seats and dashboard.

Exhilaration for all the senses.

Inside you are welcomed by two large, fully digital instruments that share the same elegant, seamless glass panel. Also new are the high-quality sports seats which give the driver and front passenger tangibly more support, allowing even more dynamic motoring without compromising on comfort.



20.0°C

0
km/h

260

568 km

1/2

0
km/h

Phone
Main Telefon

Navigation
Chicago

14:07



AIRBAG



Get in. Then get out
feeling more relaxed.

You can choose from 64 ambient colours as well as a range of different interior fragrances and massage programmes in the new GLE Coupé. Or activate an ENERGIZING programme such as “Vitality”, in which case all these comfort features are synchronised automatically.

The background image is a blurred, low-angle shot of a modern interior space, likely a train or subway station. The scene is characterized by warm, golden-brown lighting and significant motion blur, suggesting a fast-moving environment. The perspective is from a low vantage point, looking down a long, brightly lit corridor or platform. The overall mood is dynamic and energetic, emphasizing speed and movement.

The new GLE Coupé.
An expression of inner strength.





Head-up Display.

The best outlook for sporty driving enjoyment and an assured driving experience: the Head-up Display transforms your windscreen into a stunning digital cockpit, giving you a direct and uninterrupted view of key information. Your full attention remains on the road and the traffic conditions in front of you.

Driving Assistance package Plus.

The Driving Assistance package Plus offers maximum comfort and safety on the road to autonomous driving. Supplementing the Driving Assistance package is Active Stop-and-Go Assist, which can take the strain out of motorway driving. A further benefit of this package is PRE-SAFE® Impulse Side, which can provide additional protection in side collisions caused by other vehicles.



Widescreen Cockpit.

Inspirational design meets a fully digital display with flexible presentation options: the Widescreen Cockpit enables information to be truly experienced. The desired content can be positioned individually and the host of functions controlled intuitively thanks to touch technology.

MBUX Augmented Reality Navigation.

To enable you to find your way in complex traffic situations, MBUX Augmented Reality Navigation connects the virtual world with the real world. The technology incorporates graphic navigation instructions and traffic information into live images. You can get to your destination quickly, safely and stress-free.



ENERGIZING package Plus.

The ENERGIZING package is a new feature offering you comfort for all the senses. For this, premium items of equipment featuring innovative intelligence are bundled together. The result is fascinating: your Mercedes can vitalise you in specific ways. For prolonged alertness at the wheel and a highly pleasant drive.

Burmester® high-end 3D surround sound system.

Experience more performance and exclusivity with the legendary Burmester sound. The high-performance speakers deliver first-class surround sound. You can specifically optimise this for the front and rear seats to intensify the listening experience. A level of quality that is also visible, thanks to the high-quality Burmester lettering.



MULTIBEAM LED headlamps.

Perfect visibility for you: the adaptive MULTIBEAM LED headlamps with individually controllable LEDs react to the traffic situation. Partial main beam omits other road users without dazzling them. When the road is clear, the ULTRA RANGE Highbeam increases the range by 150 metres. The cornering light and active light functions also optimally light up the field of vision.



Wheels.

Another highlight: wheels of up to 55.9 cm (22 inches) in size clearly emphasise the SUV character of the new GLE Coupé.

Standard equipment and appointments.

Always confidently stylish on the road: the exterior embodies a sense of sporty passion. Characteristic SUV and coupé features result in a desirous overall image. Dominant dimensions meet elegant contours, athletic shapes meet accentuating fine details. The optimised aerodynamics form the basis for efficient, smooth travel. The progressively designed interior embodies a sense of elegant sportiness. Harmonious dimensions, high-quality materials and practical details result in a dynamic ambience for a sense of stylish comfort when on the road. Standard on-board features include: sports seats, multifunction sports steering wheel, Widescreen Cockpit and the MBUX multimedia system.



The AMG Line.

Expressive styling for an impressive appearance: the AMG Line exterior sharpens the sporty character of your vehicle and clearly differentiates it from the base model. The visual effects make your vehicle look lower and more dynamic. So you can make a clear statement for powerful design. The AMG Line interior lends your vehicle a more visible and tangible sense of sportiness. So you can make a tasteful statement and demonstrate your passion for an ambience which is dynamic and exclusively designed down to the finest detail.



The Night package.

With the AMG Night package, selected exterior elements are finished in high-gloss black. Depending on the selected paint colour, this results in either strong contrasts or flowing transitions. Whether you go for exciting highlights or prefer to demonstrate a quietly confident reserve, both options show your appreciation of individual, dynamic design.



EXCLUSIVE interior.

The EXCLUSIVE interior allows you to show what matters to you: the utmost in elegance and top-class quality down to the most minute detail. Luxurious highlights in leather and wood characterise the fine atmosphere of your interior and help to express your good taste. With the comfort seats you can also enjoy exceptional of comfort on long journeys and arrive relaxed at your destination.





AIRMATIC package.

In the AIRMATIC package, an adaptive damping system meets sophisticated air suspension. The result: an intelligent comfort suspension which is able to adjust automatically to the driving conditions, speed and load. As a result you benefit from counterbalancing driving stability with first-class comfort on both good and bad roads.



E-ACTIVE BODY CONTROL.

Superior ride comfort in any situation: E-ACTIVE BODY CONTROL is the synthesis of comfort, precision and dynamism – combined with unique off-road qualities. Experience the first-class effects of a sophisticated, fully active suspension designed to compensate for pitch, roll and shocks. On all roads and off the road. In both good and bad driving conditions.

Not an SUV. An AMG.

Every Mercedes-AMG is a masterpiece in its own right, with an unmistakable character. What unites our performance vehicles and sports cars is their irrepressible sporting spirit. Their passion for top performance. It is generated at the point where engineering skill meets a very special attitude: the spirit of AMG. We believe that you have to keep on challenging limits in order to achieve new goals. We accept nothing as a given. Because limits are imposed by people, and it's also people who can overcome them. It's this attitude that enables us to achieve outstanding performance for the race track – and for the road.

Welcome to the world of AMG.

www.mercedes-amg.com

DRIVING PERFORMANCE



Technical data.

Displacement (cc)
Rated output ¹ (kW [hp] at rpm)
Acceleration from 0 to 100 km/h (s)
Top speed (km/h)
Fuel consumption ⁴ (l/100 km)
Urban
Extra-urban
Combined
Combined CO ₂ emissions ⁴ (g/km)
Emissions class ⁵ /efficiency class ⁶

Petrol engines

GLE 450	Mercedes-AMG GLE 53 4MATIC	Mercedes-AMG GLE 63 4MATIC	Mercedes-AMG GLE 63 S 4MATIC
2999	2999	3982	3982
270 (367) 5500-6100	320 (435) 5500-6100	420 (571) 5750-6500	450 (612) 5750-6500
5.7	5.3	4.0	3.8
250	250	250	280
11.9-11.4	12.5-12.5	15.2-15.2	15.2-15.2
7.5-6.8	7.9-7.9	9.3-9.3	9.3-9.3
9.1-8.5	9.6-9.6	11.4-11.4	11.5-11.5
208.0-195.0	219.0-219.0	262.0-262.0	263.0-263.0
Euro 4/ C	Euro 4/ D	Euro 4/ E	Euro 4/ E

The best for the engine:
Mercedes-Benz genuine engine oils.

¹ Information about the rated output according to Regulation (EC) No. 715/2007 in the currently valid version. ² Available temporarily. ³ Electronically governed. ⁴ The stated figures were determined according to the prescribed measurement method. They constitute the "NEDC CO₂ figures" pursuant to Article 2 No. 1 Implementing Regulation (EU) 2017/1153. Fuel consumption figures have been calculated on this basis. More information about the official fuel consumption and the official specific CO₂ emissions of new passenger cars is available in the publication entitled "Leitfaden über den Kraftstoffverbrauch, die CO₂-Emissionen und den Stromverbrauch neuer Personenkraftwagen" ["Guidelines concerning the fuel consumption, CO₂ emissions and electricity consumption of new passenger cars"], available free of charge at all retailers and from Deutsche Automobil Treuhand GmbH (www.dat.de). The figures are not based on an individual vehicle and do not constitute part of the product offer; they are provided solely for purposes of comparison between different vehicle models. The figures will vary according to the optional equipment selected. ⁵ Information only valid within the European Union. May vary from country to country. ⁶ Determined on the basis of the measured CO₂ emissions, taking into consideration the vehicle mass. Only valid for Germany. *Weighted electrical consumption (kWh/100 km)/Electric range (km): XXXXXXXX.
Further technical data may be found at

Dimensions.

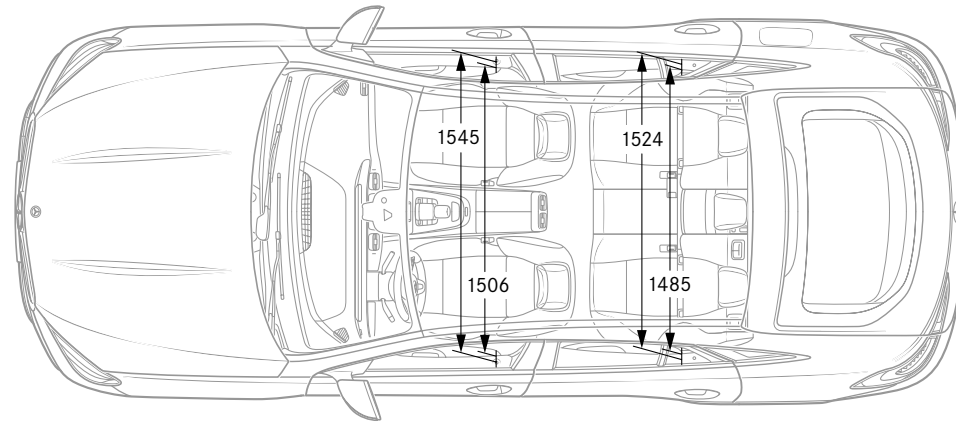
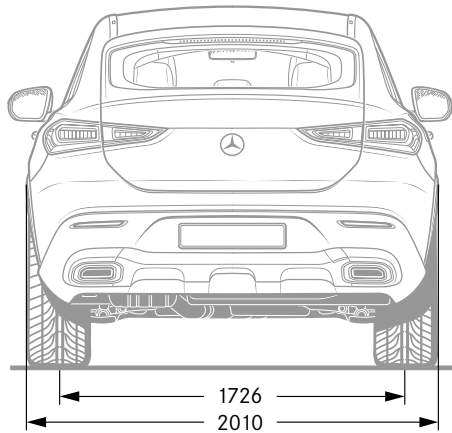
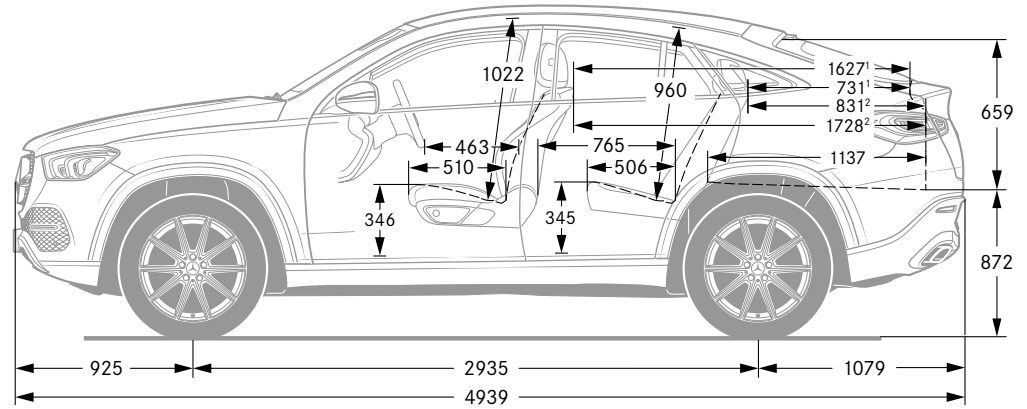
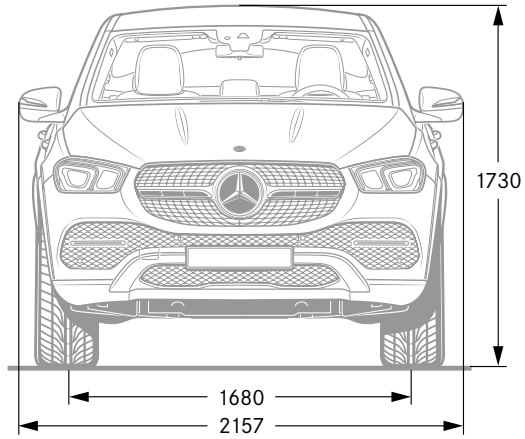

¹ Up to parcel shelf connecting edge. ² Below the parcel shelf. All figures in millimetres. The illustrated dimensions are mean values. They are valid for vehicles in basic specification and in unladen condition.



SPORT — F O R — GOOD

Mercedes-Benz is one of the founding partners of the worldwide “Laureus Sport for Good Foundation”, which was established in 2000. It is the Mercedes-Benz brand’s most important social initiative. Laureus Sport for Good supports children and young people in need through social sports projects, opening up new perspectives and imparting important values such as team spirit, respect and determination. “Change the Game for Kids” is our mission statement which we wish to share with you.

Please note: changes may have been made to the product since the editorial deadline (27.09.2019). The manufacturer reserves the right to make changes to the design, form, colour and the product specification during the delivery period, provided these changes, while taking into account the interests of the vendor, can be deemed reasonable with respect to the purchaser. Where the seller or the manufacturer uses symbols or numbers to describe an order or the subject of

an order, no rights may be derived solely from these. The illustrations may show accessories and items of optional equipment which are not part of standard specification. For current and more specific information, please contact your nearest authorised Mercedes-Benz sales partner.